

UNIT DESCRIPTION	
MODEL #	T3-DX-3PH
WEIGHT	955 lb
DISCHARGE DIRECTION	DOWN
AIRFLOW (CFM)	4000
EXTERNAL SP	.25
TOTAL SP	1.78
FAN BHP	1.84
FAN RPM	969
MOTOR HP	2 HP
HEATING TYPE	DIRECT GAS FIRED
FUEL TYPE	NATURAL GAS
INPUT (MBH)	352
OUTPUT (MBH)	324
POWER SUPPLY	208/3/60
FLA (AMPS)	10.5
MCA (AMPS)	12.4
MOP (AMPS)	15
SELECTION DATA	
AIRFLOW	4000 CFM
ELEVATION	1033 FT
ENTERING DB/WB	93.9°F / 74.8°F
REQ'D LEAVING AIR DB/WB	0°F / 0°F
REQ'D CAPACITY	120 MBH
COILS PER BANK	1
FIN TYPE	5/8" 1.5" X 1.299" WAFLE
FIN HEIGHT	30"
FIN LENGTH	42"
FIN MATERIAL	ALUMINUM .006 in.
TUBE MATERIAL	COPPER 0.020 in.
REFRIGERANT	R454b
LIQUID TEMP	110°F
EVAP. TEMP	56°F
LEAVING SUPERHEAT	5°F
COIL CIRCUITING	INTERLACE 2 CIRCUIT
COIL HAND	RIGHT HAND
CASING MATERIAL	16 ga. GALVANIZED
CONNECTION MATERIAL	COPPER
CONNECTION TYPE	SWT
COIL COATING	NONE
PERFORMANCE DATA	
MODEL	DXC03C11-30.00 X 42.00R
ROWS/FBI	3 / 11.0
TOTAL CAPACITY	93.4 MBH
SENSIBLE CAPACITY	72.0 MBH
LEAVING AIR DB/WB	72.8°F / 67.0°F
FACE VELOCITY	457.14 FPM
REFRIGERANT CHARGE	4.61 lbs
AIR PRESSURE DROP	0.33" WC
REFRIGERANT PRESSURE DROP	2.92 PSI
TOTAL FEEDS	5 FEEDS
TUBE VAPOR VELOCITY	1574 FPM
SUCTION CONNECTION	1.125"
SUCTION LINE VELOCITY	1175 FPM
DISTRIBUTOR #1	502-2-5/16-3
DISTRIBUTOR #2	501-3-1/4-3
HOT GAS BYPASS CONNECTION	(1) PER DISTRIBUTOR
DRY WEIGHT	92.1 lbs.

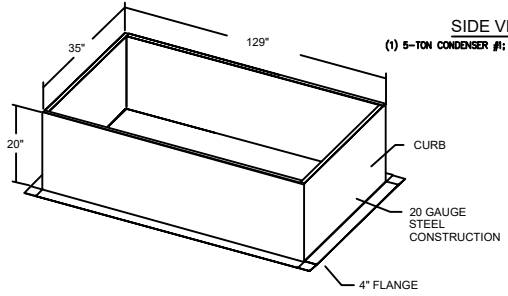
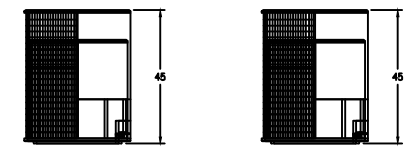
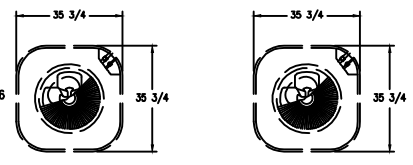
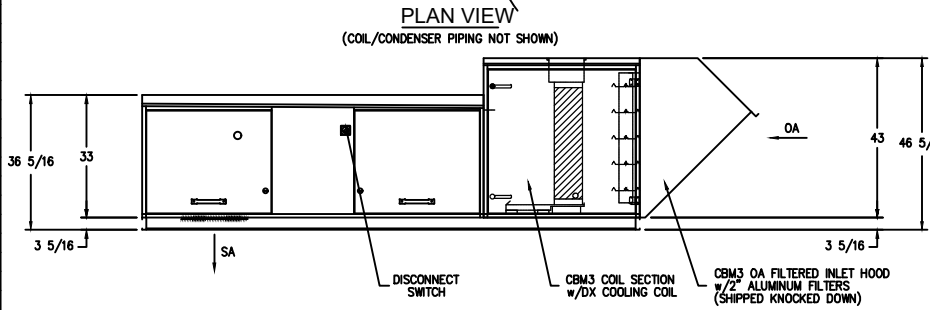
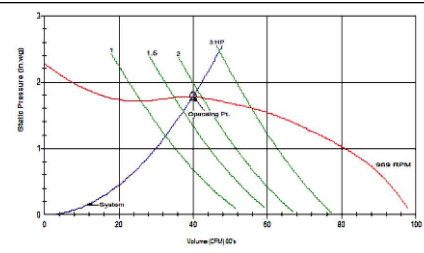
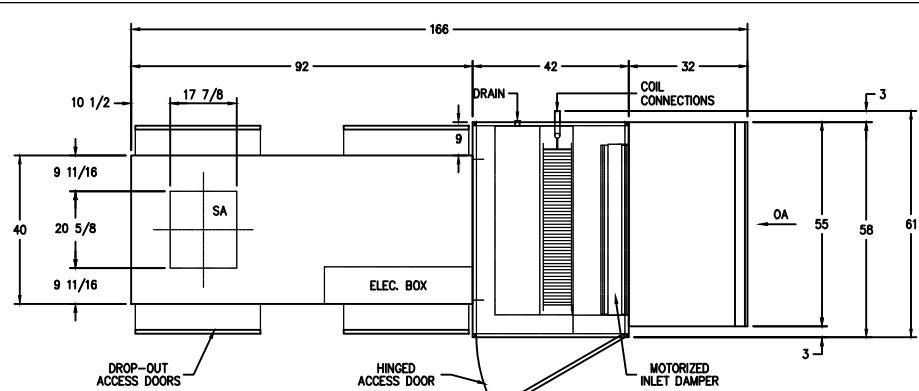

(1) 5-TON CONDENSER #1; APPROX. 266 LBS. (1) 5-TON CONDENSER #2; APPROX. 266 LBS.

"IT IS THE RESPONSIBILITY OF THE ARCHITECT/OWNER TO ENSURE THAT THE HOODS RELEASE FROM LIMITED-COMBUSTIBLE MATERIALS IN COMPLIANCE WITH LOCAL CODE REQUIREMENTS."

"ALL EQUIPMENT IS UL LISTED COMPONENTS. NAKS HOODS ARE BUILT IN COMPLIANCE WITH: NFPA 96 & UL710 AND ARE RECOGNIZED BY ONE OR MORE OF THE FOLLOWING - NSF INTERNATIONAL -UL -OPENINGS ARE RECOMMENDED SIZES. DUCT OPENINGS TO BE CUT AND DUCTS INSTALLED IN FIELD."



FAN UNIT NO.	FAN UNIT MODEL #	EXHAUST FAN									SUPPLY FAN									
		MODEL	TAG	CFM	S.P.	RPM	H.P.	Ø	VOLT	FLA	BLOWER	HOUSING	TAG	CFM	S.P.	RPM	H.P.	Ø	VOLT	FLA
-	T3-DX SF-1	-	-	-	-	-	-	-	-	-	-	T3-DX	SF-1	4000	0.25	969	2.0	3	230	-

REVISIONS	

NORTH AMERICAN SOLUTIONS	
172 BEAVER CREEK	1704 E. 17th Ave. • Denver, CO 80202
TEL: 303-751-1000	FAX: 303-751-1000
EQUIPMENT SCHEDULE	
CONTRACT NO. -	ITEM NO. -
LOC. -	
DATE -	
DWG# -	SHT -
	OF -