

UNIT DESCRIPTION	
MODEL #	SF7-DX
WEIGHT	575 lb
DISCHARGE DIRECTION	DOWN
AIRFLOW (CFM)	2000
EXTERNAL SP	.25
TOTAL SP	1.23
FAN BHP	0.84
FAN RPM	1115
MOTOR HP	1 HP
POWER SUPPLY	208/3/60
FLA (AMPS)	7.6
MCA (AMPS)	8.8
MOP (AMPS)	12
SELECTION DATA	
AIRFLOW	2000 CFM
ELEVATION	1033 FT
ENTERING DB/WB	93.9°F / 74.8°F
REQ'D LEAVING AIR DB/WB	0°F / 0°F
REQ'D CAPACITY	60 MBH
COILS PER BANK	1
FIN TYPE	5/8" 1.5" X 1.299" WAFFLE
FIN HEIGHT	21"
FIN LENGTH	27"
FIN MATERIAL	ALUMINUM .006 in.
TUBE MATERIAL	COPPER 0.020 in.
REFRIGERANT	R454b
LIQUID TEMP	110°F
EVAP. TEMP	56°F
LEAVING SUPERHEAT	5°F
COIL CIRCUITING	SINGLE CIRCUIT
COIL HAND	RIGHT HAND
CASING MATERIAL	16 ga. GALVANIZED
CONNECTION MATERIAL	COPPER
CONNECTION TYPE	SWT
COIL COATING	NONE
PERFORMANCE DATA	
MODEL	DXC03C13-21.00 X 27.00R
ROWS/FBI	3 / 13.0
TOTAL CAPACITY	61.3 MBH
SENSIBLE CAPACITY	47.4 MBH
LEAVING AIR DB/WB	72.5°F / 67.0°F
FACE VELOCITY	507.94 FPM
REFRIGERANT CHARGE	2.02 lbs
AIR PRESSURE DROP	0.43" WC
REFRIGERANT PRESSURE DROP	5.07 PSI
TOTAL FEEDS	2 FEEDS
TUBE VAPOR VELOCITY	1969 FPM
SUCTION CONNECTION	1.125"
SUCTION LINE VELOCITY	1470 FPM
DISTRIBUTOR #1	502-2-5/16-3
HOT GAS BYPASS CONNECTION	(1)PER DISTRIBUTOR
DRY WEIGHT	49.3 lbs.

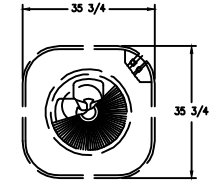

PLAN VIEW - CONDENSER (SHIPPED LOOSE)

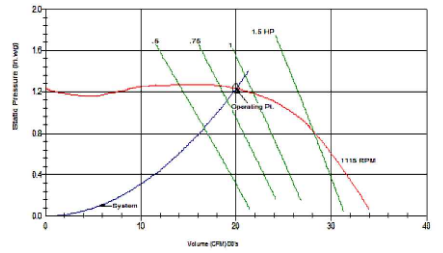
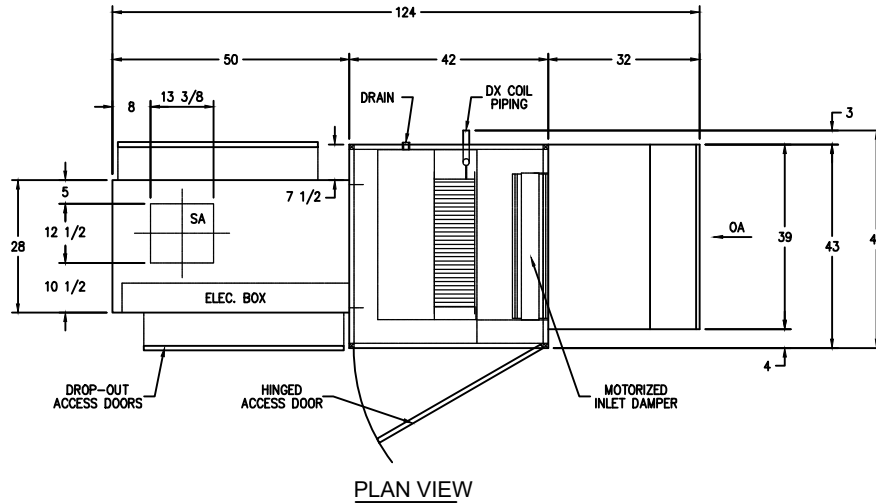
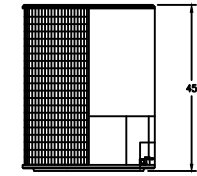

SIDE VIEW - CONDENSER (SHIPPED LOOSE)
(1) 5-TON CONDENSER; APPROX. 266 LBS.

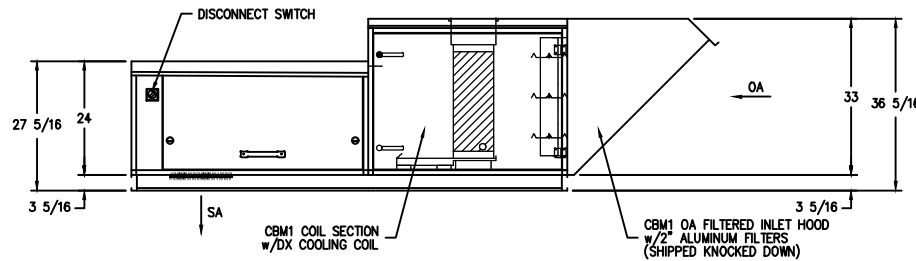

CONTROLS SIDE VIEW

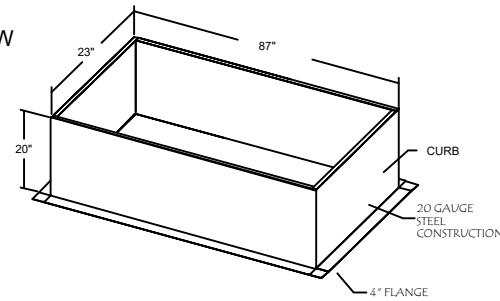

"IT IS THE RESPONSIBILITY OF THE ARCHITECT/OWNER TO ENSURE THAT THE HOOD IS CLEARANCE FROM LIMITED-COMBUSTIBLE MATERIALS IN COMPLIANCE WITH LOCAL CODE REQUIREMENTS."

"ALL EQUIPMENT IS UL LISTED COMPONENTS. NAKS HOODS ARE BUILT IN COMPLIANCE WITH: NFPA 96 & UL710 AND ARE RECOGNIZED BY ONE OR MORE OF THE FOLLOWING - NSF INTERNATIONAL -UL -OPENINGS ARE RECOMMENDED SIZES, DUCT OPENINGS TO BE CUT AND DUCTS INSTALLED IN FIELD"



FAN UNIT NO.	FAN UNIT MODEL #	EXHAUST FAN									SUPPLY FAN									
		MODEL	TAG	CFM	S.P.	RPM	H.P.	Ø	VOLT	FLA	BLOWER	HOUSING	TAG	CFM	S.P.	RPM	H.P.	Ø	VOLT	FLA
-	SF7-DX SF-1	-	-	-	-	-	-	-	-	-	-	SF7-DX	SF-1	2000	0.25	1115	0.50	3	230	-

REVISIONS		NORTH AMERICAN FILTER SOLUTIONS	
NO.	DESCRIPTION	152 READER COURT EVANSTON, OH 44020	TEL: 440-885-1100 FAX: 440-885-2300
EQUIPMENT SCHEDULE			
CONTRACT NO. -		ITEM NO. -	
LOC. -		DATE -	
DWG# -		SHT -	
		OF -	