

UNIT DESCRIPTION	
MODEL #	SF5-DX
WEIGHT	575 lb
DISCHARGE DIRECTION	DOWN
AIRFLOW (CFM)	1212
EXTERNAL SP	.25
TOTAL SP	.95
FAN BHP	0.33
FAN RPM	966
MOTOR HP	1/2 HP
POWER SUPPLY	208/1/60
FLA (AMPS)	8.4
MCA (AMPS)	9.8
MOP (AMPS)	15
SELECTION DATA	
AIRFLOW	1212 CFM
ELEVATION	1033 FT
ENTERING DB/WB	93.9°F / 74.8°F
REQ'D LEAVING AIR DB/WB	0°F / 0°F
REQ'D CAPACITY	36 MBH
COILS PER BANK	1
FIN TYPE	5/8" 1.5" X 1.299" WAFFLE
FIN HEIGHT	21"
FIN LENGTH	27"
FIN MATERIAL	ALUMINUM .006 in.
TUBE MATERIAL	COPPER 0.020 in.
REFRIGERANT	R454b
LIQUID TEMP	110°F
EVAP. TEMP	57°F
LEAVING SUPERHEAT	5°F
COIL CIRCUITING	SINGLE CIRCUIT
COIL HAND	RIGHT HAND
CASING MATERIAL	16 ga. GALVANIZED
CONNECTION MATERIAL	COPPER
CONNECTION TYPE	SWT
COIL COATING	NONE
PERFORMANCE DATA	
MODEL	DXC03C09-21.00 X 27.00R
ROWS/FBI	3 / 9.0
TOTAL CAPACITY	36.8 MBH
SENSIBLE CAPACITY	28.2 MBH
LEAVING AIR DB/WB	72.9°F / 67.1°F
FACE VELOCITY	307.81 FPM
REFRIGERANT CHARGE	2.12 lbs
AIR PRESSURE DROP	0.15" WC
REFRIGERANT PRESSURE DROP	1.95 PSI
TOTAL FEEDS	2 FEEDS
TUBE VAPOR VELOCITY	1157 FPM
SUCTION CONNECTION	0.875"
SUCTION LINE VELOCITY	1536 FPM
DISTRIBUTOR #1	501-2-1/4-2
HOT GAS BYPASS CONNECTION	(1) PER DISTRIBUTOR
DRY WEIGHT	44.5 lbs.

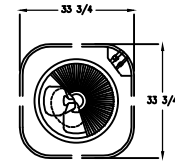

PLAN VIEW - CONDENSER (SHIPPED LOOSE)

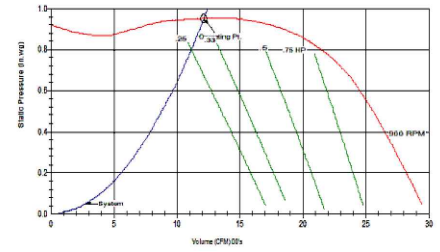
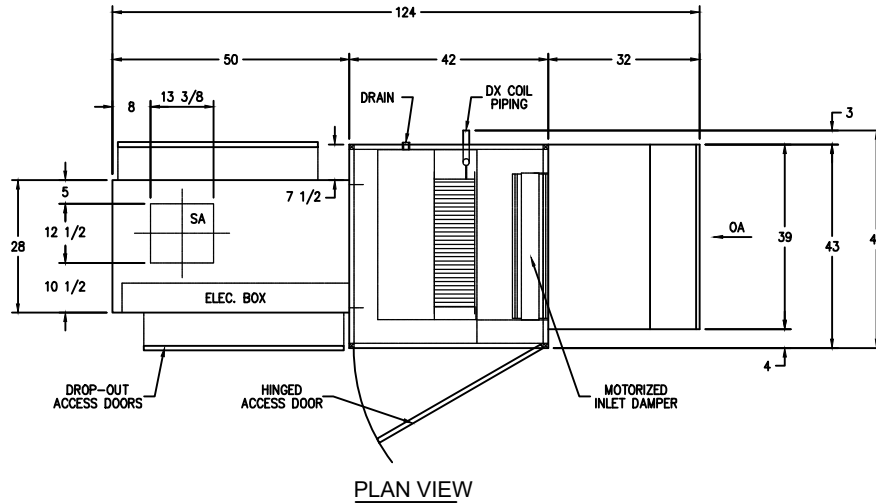
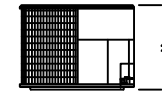

SIDE VIEW - CONDENSER (SHIPPED LOOSE)
(1) 3-TON CONDENSER; APPROX. 166 LBS.

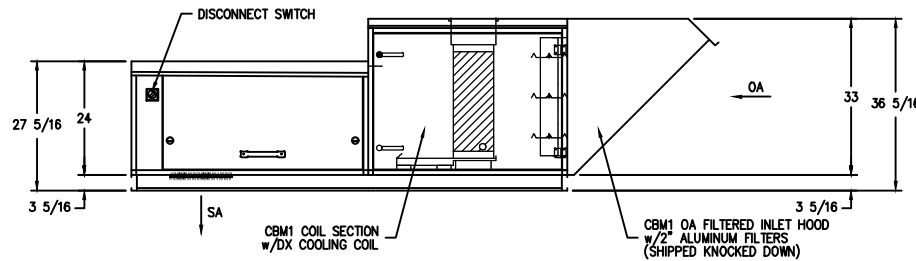

CONTROLS SIDE VIEW

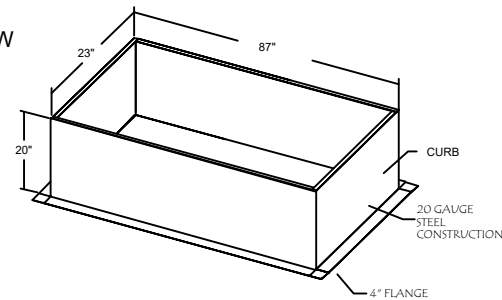

"IT IS THE RESPONSIBILITY OF THE ARCHITECT/OWNER TO ENSURE THAT THE HOOD CLEARANCE FROM LIMITED-COMBUSTIBLE MATERIALS IS IN COMPLIANCE WITH LOCAL CODE REQUIREMENTS."

"ALL EQUIPMENT IS UL LISTED COMPONENTS. NAKS HOODS ARE BUILT IN COMPLIANCE WITH: NFPA 96 & UL710 AND ARE RECOGNIZED BY ONE OR MORE OF THE FOLLOWING - NSF INTERNATIONAL -UL -OPENINGS ARE RECOMMENDED SIZES. DUCT OPENINGS TO BE CUT AND DUCTS INSTALLED IN FIELD"



FAN UNIT NO.	FAN UNIT MODEL #	EXHAUST FAN									SUPPLY FAN									
		MODEL	TAG	CFM	S.P.	RPM	H.P.	Ø	VOLT	FLA	BLOWER	HOUSING	TAG	CFM	S.P.	RPM	H.P.	Ø	VOLT	FLA
-	SF5-DX SF-1	-	-	-	-	-	-	-	-	-	-	SF5-DX	SF-1	1212	0.25	976	0.50	1	230	-

REVISIONS		NORTH AMERICAN FILTER SOLUTIONS	
NO.	DESCRIPTION	172 BEAVER CREEK	1704 FERRIS
		EVANSTON, OHIO 44129	EVANSTON, OHIO 44129
		TEL: 440-885-2800	FAX: 440-885-2700
EQUIPMENT SCHEDULE			
SF5-DX			
CONTRACT NO. -		ITEM NO. -	
LOC. -		DATE -	
DWG# -		SHT -	
		OF -	