

UNIT DESCRIPTION	
MODEL #	SF11-DX
WEIGHT	1045 lb
DISCHARGE DIRECTION	DOWN
AIRFLOW (CFM)	5000
EXTERNAL SP	.25
TOTAL SP	1.12
FAN BHP	1.87
FAN RPM	822
MOTOR HP	3 HP
POWER SUPPLY	208/3/60
FLA (AMPS)	15.6
MCA (AMPS)	16.3
MOP (AMPS)	25
SELECTION DATA	
AIRFLOW	5000 CFM
ELEVATION	1033 FT
ENTERING DB/WB	93.9°F / 74.8°F
REQ'D LEAVING AIR DB/WB	0°F / 0°F
REQ'D CAPACITY	120 MBH
COILS PER BANK	1
FIN TYPE	5/8" x 1.5" X 1.299" WAFFLE
FIN HEIGHT	33"
FIN LENGTH	50"
FIN MATERIAL	ALUMINUM .006 in.
TUBE MATERIAL	COPPER 0.020 in.
REFRIGERANT	R454b
LIQUID TEMP	110°F
EVAP. TEMP	61°F
LEAVING SUPERHEAT	5°F
COIL CIRCUITING	INTERLACE 2 CIRCUIT
COIL HAND	RIGHT HAND
CASING MATERIAL	16 ga. GALVANIZED
CONNECTION MATERIAL	COPPER
CONNECTION TYPE	SWT
COIL COATING	NONE
PERFORMANCE DATA	
MODEL	DXC03C12-33.00 X 50.00R
ROWS/FBI	3 / 12.0
TOTAL CAPACITY	120.6 MBH
SENSIBLE CAPACITY	111.0 MBH
LEAVING AIR DB/WB	73.9°F / 68.8°F
FACE VELOCITY	436.36 FPM
REFRIGERANT CHARGE	6.28 lbs
AIR PRESSURE DROP	0.32" WC
REFRIGERANT PRESSURE DROP	5.64 PSI
TOTAL FEEDS	4 FEEDS
TUBE VAPOR VELOCITY	1747 FPM
SUCTION CONNECTION	1.125"
SUCTION LINE VELOCITY	1304 FPM
DISTRIBUTOR #1	501-2-1/4-3
DISTRIBUTOR #2	501-3-1/4-3
HOT GAS BYPASS CONNECTION	(1) PER DISTRIBUTOR
DRY WEIGHT	116.4 lbs.

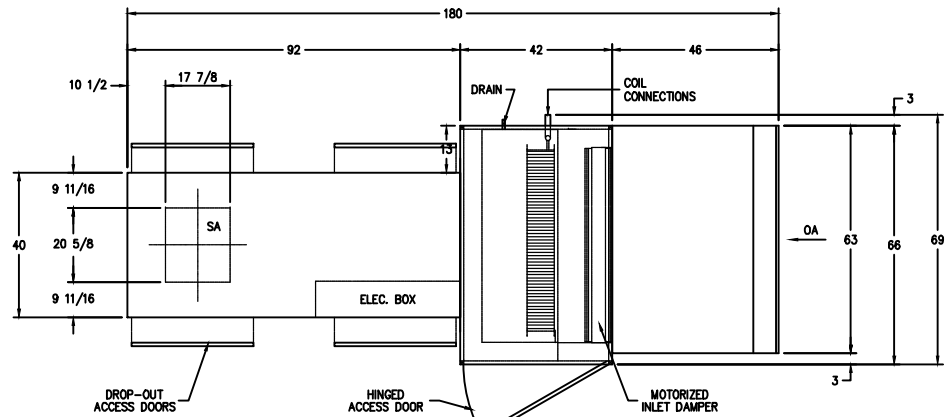

PLAN VIEW

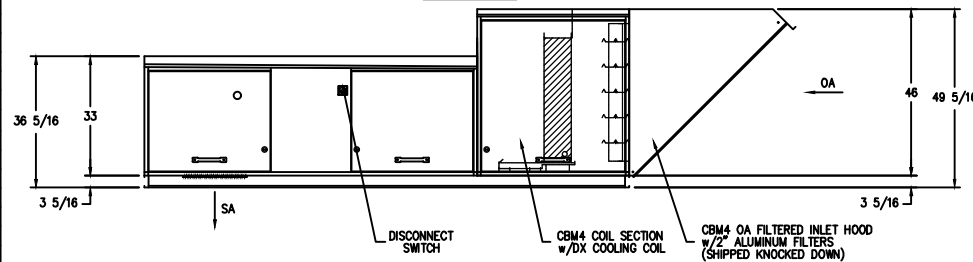

CONTROLS SIDE VIEW

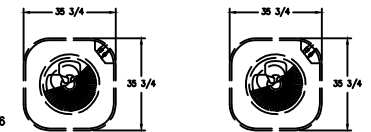
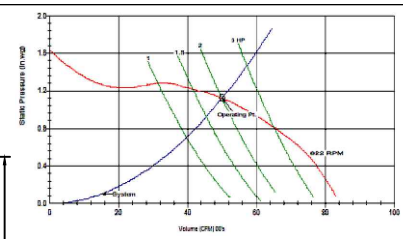

PLAN VIEW - CONDENSERS (SHIPPED LOOSE)

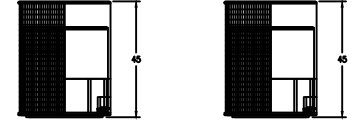

SIDE VIEW - CONDENSERS (SHIPPED LOOSE)  
(1) 5-TON CONDENSER #1: APPROX. 206 LBS. (1) 5-TON CONDENSER #2: APPROX. 206 LBS.

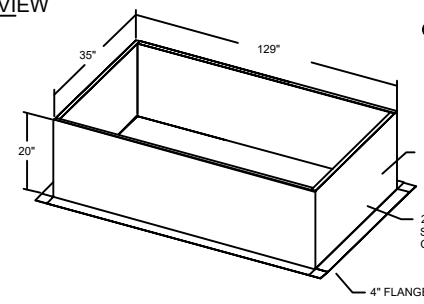

"IT IS THE RESPONSIBILITY OF THE ARCHITECT/OWNER TO ENSURE THAT THE HOOD IS COMPLIANT FROM LIMITED-COMBUSTIBLE MATERIALS IN COMPLIANCE WITH LOCAL CODE REQUIREMENTS."

"ALL EQUIPMENT IS UL LISTED COMPONENTS. NAKS HOODS ARE BUILT IN COMPLIANCE WITH: NFPA 96B & UL710 AND ARE RECOGNIZED BY ONE OR MORE OF THE FOLLOWING - NSF INTERNATIONAL -UL -OPENINGS ARE RECOMMENDED SIZES, DUCT OPENINGS TO BE CUT AND DUCTS INSTALLED IN FIELD"



FAN UNIT NO.	FAN UNIT MODEL #	EXHAUST FAN									SUPPLY FAN									
		MODEL	TAG	CFM	S.P.	RPM	H.P.	Ø	VOLT	FLA	BLOWER	HOUSING	TAG	CFM	S.P.	RPM	H.P.	Ø	VOLT	FLA
-	SF11-DX SF-1	-	-	-	-	-	-	-	-	-	-	SF11-DX	SF-1	5000	0.25	822	3	3	230	-

REVISIONS		NORTH AMERICAN ELECTRICAL SOLUTIONS INTERNATIONAL			
NO.	DATE	BY	CHKD	172 REAPER CIRCLE EVANSTON, OH 44024-6800	TEL: 440-884-6307 FAX: 440-884-2700
EQUIPMENT SCHEDULE				CONTRACT NO. - - - - - ITEM NO. - - - - -	
SF11-DX				LOC. - - - - -	
				QUANTITY - - - - -	
				DATE - - - - -	
DWG# - - - - -				SHT - - - - -	
				OF - - - - -	